



MODEL 310 GAS AMMONIATOR

The principal use of the REGAL Gas Ammoniator is to provide a chloramination disinfection process.

The REGAL Model 310 Ammoniator is a vacuum-operated solution feed system designed for mounting directly to the valve of a REGAL MAN-1A wall mounted ammonia manifold assembly. The MAN-1A manifold includes a 30" long flexible connector (MS-30) and a yoke assembly (Y-150A) for connection to the outlet valve of the ammonia cylinder (see typical installation drawings). A highly efficient water operated, vacuum-producing ejector is close coupled with the ammonia solution diffuser. The ejector contains a back flow check valve. Ammonia gas flow rate is manually set using the rate adjustment valve and regulated by a spring opposed diaphragm regulator which is also the safety shut-off valve.

APPLICATIONS

The REGAL Ammoniator is designed to handle the vast majority of water treatment requirements.

IN THE POTABLE WATER INDUSTRY: odor and color control, prevention of disinfection by-products formation, and extension of the disinfection process through large distribution networks by the formation of chloramines.

IN WASTEWATER: helping to improve the environment for aerobic organisms, through the introduction of nitrogen.

IN THE PETROLEUM INDUSTRY: neutralizing acid-treated crude oils, removing sulfur and preventing corrosion in stills, condensers and coolers.

IN THE PAPER INDUSTRY: preventing slime as a base for sulfite pulping process.

IN THE TEXTILE INDUSTRY: ammonia is used in wool processing.

IN ALL INDUSTRIES: it is used to neutralize acids.

FEATURES

The REGAL Ammoniator incorporates the very best available materials with the latest technology in design and construction to reduce maintenance, simplify construction and improve operation.



CAPACITIES

Variable area flow metering tubes are available with maximum capacities of 4, 10, 25, 50 and 100 pounds of ammonia gas per 24 hrs. Metric scales are available with maximum capacities of 75, 200, 500, 1000 and 2000 grams per hr.

FLOW RATE ADJUSTMENT

Manually adjustable by means of a flow rate control valve located at the top of the flow meter. Flow rate is then regulated by a special spring-opposed diaphragm operated valve. The system is automatic. It will go off and on as the ejector supply water is turned off and on and will always return to the pre-set flow rate.

MATERIALS OF CONSTRUCTION

All materials used in REGAL gas ammoniators have been carefully chosen for their excellent corrosion-resistant, ultra-violet-resistant properties plus their ability to withstand stresses far greater than will be encountered in actual use.

EJECTOR REQUIREMENTS

The standard ejector is designed to withstand static back pressures up to 200 psig (14.1 kg/cm²). Generally, the amount of water required to operate the ejector depends upon the ammonia gas flow rate. The higher the flow rate, the greater the water flow needed.

OPERATION

The ammoniator is clamped onto the valve of the REGAL MAN-1A wall mounted ammonia manifold assembly. The MAN-1A is connected to the ammonia cylinder valve using a lead gasket seal between the flexible connector/yoke assembly and the cylinder valve outlet. A vacuum line (provided) connects the ejector to the ammoniator.

Water, under pressure, is forced through the ejector nozzle which creates a strong vacuum in the ejector body. This pulls gas into the ejector through a special back-flow check valve and then into the nozzle outlet. The gas mixes with the ejector water and is discharged through the diffuser into the water being treated.

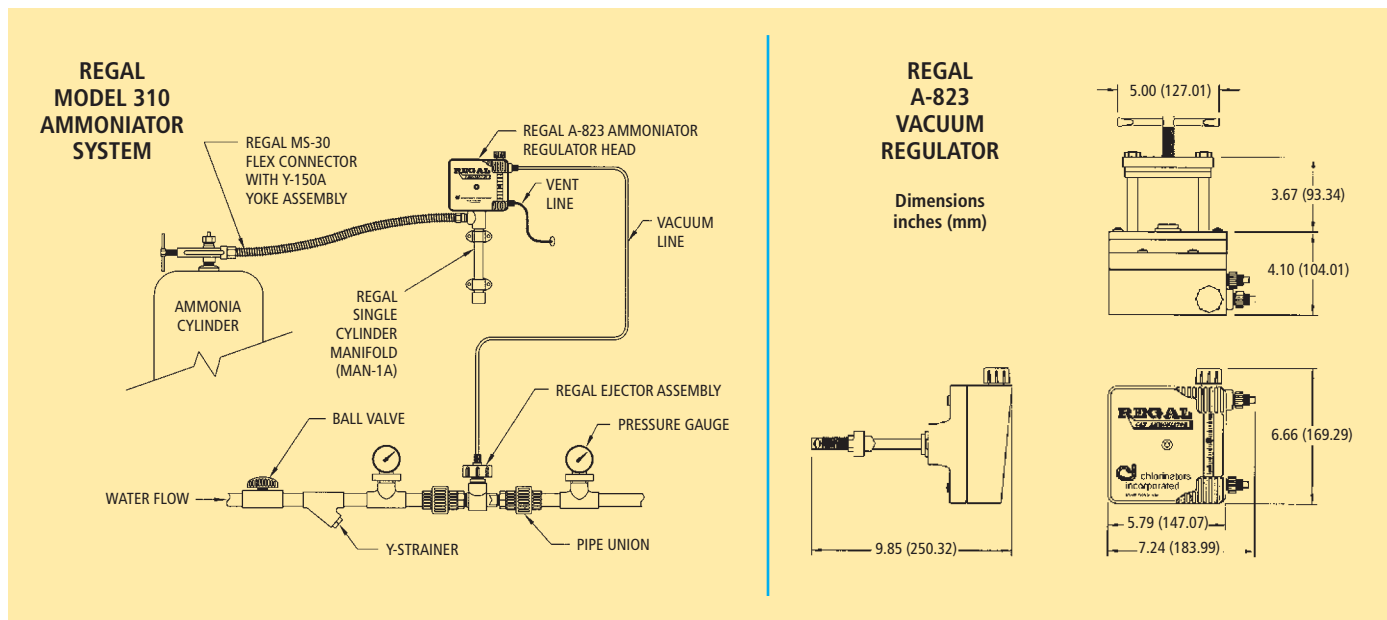

OPERATION (continued)

The ejector vacuum is transmitted back to the ammoniator through the vacuum line; then through the rate valve and the flow meter and to the back of the diaphragm. With sufficient vacuum, the diaphragm moves backward, opening the spring loaded inlet regulating valve to allow ammonia gas to enter from the cylinder. The ammonia passes through the flow rate indicating meter, flow rate adjusting valve and to the ejector.

SPECIFICATIONS

The ammoniator shall be a vacuum operated, solution feed type for mounting directly on the valve of the REGAL MAN-1A wall mounted manifold assembly. It shall be a REGAL Model 310 manufactured by Chlorinators Incorporated, Stuart, Florida and shall have a maximum capacity of 100 lbs./24 hrs. (2000 gms/hr).

The REGAL MAN-1A ammonia manifold connects to the cylinder valve by means of a positive yoke type clamp which is part of the MAN-1A manifold.

All regulating, metering, flow adjusting and safety functions shall be incorporated in the ammoniator regulator.

The inlet safety shut-off/vacuum regulating valve shall be of capsulated construction, easily removable as a unit from the outlet side of the ammoniator for ease of inspection, cleaning or maintenance.

Vacuum shall be created by an ejector assembly connected directly to the ammonia solution diffuser. The assembly shall consist of a single piece venturi nozzle-recovery throat to prevent misalignment; also, a back flow check valve to prevent water from entering the gas system. The check valve shall be of positive, tight shut-off, unitized design not requiring springs or diaphragms for tight closing.

CONTENTS GUIDE

Model 310

- 1 each Model A-823 Vacuum Regulator with 3/8" Vent and Vacuum Fittings
- 1 each Model A-920A Ejector Assembly includes Nozzle, High Pressure Check Valve, Spray Diffuser and 3/8" Vacuum Fitting
- 25' VT-1 3/8" Vent and Vacuum Tubing
- 10 each G-201 Lead Cylinder Gaskets
- 1 each Z-296 Rate Valve Tool
- 1 each Z-297 Vent Line Bug Screen
- Approximate Shipping Weight: 8 lbs

Model 310-1 - Direct Cylinder Mounted, Vacuum Operated with Remote Meter Assembly

- 1 each Model A-803 Vacuum Regulator with 3/8" Vent and Vacuum Fittings. Rate Valve removed and opening plugged. Valve is on remote meter panel. Metering tube assembly replaced with plain glass tube.
- 1 each Model A-255A Remote Meter Panel with 3/8" Vacuum Fittings (for wall mounting)
- 1 each Model A-920A Ejector Assembly includes Nozzle, High Pressure Check Valve, Spray Diffuser and 3/8" Vacuum Fitting
- 50' VT-1 3/8" Vent and Vacuum Tubing
- 10 each G-201 Lead Cylinder Gaskets
- 1 each Z-296 Rate Valve Tool
- 1 each Z-297 Vent Line Bug Screen
- Approximate Shipping Weight: 10 lbs

OPTIONAL

- Low Pressure Ejector A-921A
- Hi/Lo Pressure Ejector A-927A
- MAN-1A Wall Mounted Manifold Assembly

IMPORTANT NOTE: The REGAL MAN-1A Wall Mounted Ammonia Manifold Assembly is ordered as a separate line item. Consult CHLORINATORS INCORPORATED.



MODEL 316

AUTOMATIC SWITCHOVER GAS AMMONIATOR

The principal use of the REGAL Gas Ammoniator is to provide a chloramination disinfection process.

The REGAL Model 316 Automatic Switchover Gas Ammoniator is a totally vacuum-operated system which is designed to automatically switch the ammonia feed from an empty cylinder to a full cylinder providing uninterrupted supply. Therefore, it is designed to provide system back-up. The ammoniator regulators are designed for mounting directly to the valve of a REGAL MAN-1A wall mounted ammonia manifold assembly which then connect to the ammonia cylinder valves using a 30" long flexible connector/yoke assembly (see typical installation drawings). Switchover from one cylinder to the other is self-actuation, eliminating the need for a separate switchover mechanism. A separate gas flow meter and rate control valve panel may be located wherever it is most convenient for the operator and connected between the vacuum regulator junction at the pressure relief valve, and the ejector, by means of safe vacuum tubing. The ejector assembly contains a back flow check valve. Ammonia gas flow rate is regulated by a spring-opposed diaphragm regulator which is also the automatic safety shut-off valve. A pressure relief valve provides a central interconnection point for the vacuum tubing.

APPLICATIONS

The REGAL Ammoniator is designed to handle the vast majority of water treatment requirements.

IN THE POTABLE WATER INDUSTRY: odor and color control, prevention of disinfection by-products formation, and extension of the disinfection process through large distribution networks by the formation of chloramines.

IN WASTEWATER: helping to improve the environment for aerobic organisms, through the introduction of nitrogen.

IN THE PETROLEUM INDUSTRY: neutralizing acid-treated crude oils, removing sulfur and preventing corrosion in stills, condensers and coolers.

IN THE PAPER INDUSTRY: preventing slime as a base for sulfite pulping process.

IN THE TEXTILE INDUSTRY: ammonia is used in wool processing.

IN ALL INDUSTRIES: it is used to neutralize acids.



FEATURES

- The REGAL Ammoniator incorporates the very best available materials with the latest technology in design and construction to reduce maintenance, simplify construction and improve operation.
- System Back-up – Each cylinder's ammoniator has its own vacuum regulating diaphragm and safety/inlet valve insuring that ammoniation can be continued if service should be required on either chlorinator.
- Corrosion-resistant, Factory-adjusted Detent Mechanism – Detent does not require any field adjustment assuring that cylinder switchover will occur at the proper time, and that all available gas in supply cylinder will be used.
- In-Use/Stand-by Indication – Prominent indicator on face quickly tells which is the stand-by cylinder and which cylinder is in use. Optional flowmeter panels are available for applications where the feed rate must be known at the ammoniator regulators and at the remote flow meter/rate valve location.

CAPACITIES

Variable area flow metering tubes are available with maximum capacities of 4, 10, 25, 50 and 100 pounds of ammonia gas per 24 hrs. Metric scales are available with maximum capacities of 75, 200, 500, 1000 and 2000 grams per hr.

FLOW RATE ADJUSTMENT

Manually adjustable by means of a flow rate control valve located at the top of the flow meter/rate valve panel.

MATERIALS OF CONSTRUCTION

All materials used in REGAL gas ammoniators have been carefully chosen for their excellent corrosion-resistant, ultra-violet-resistant properties plus their ability to withstand stresses far greater than will be encountered in actual use.

OPERATION

The ammoniator regulators are mounted to the REGAL MAN-1A wall mounted manifolds that connect to the ammonia gas cylinders (see drawing). A vacuum line is connected from each regulator to the wall-mounted pressure-relief (vent) valve, and a single vacuum line connects the outlet of the valve to a wall-mounted, flow-meter/rate valve panel. The ejector is connected to the rate valve panel with a single vacuum line.

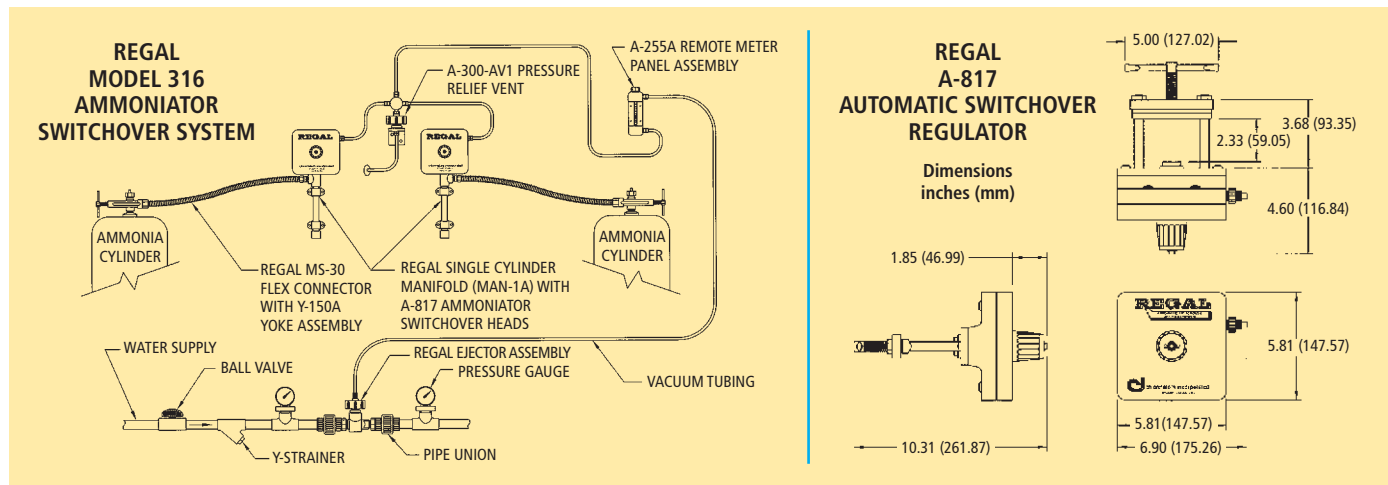

OPERATION (continued)

Water, under pressure, is forced through the ejector nozzle which creates a strong vacuum in the ejector body. This pulls gas into the ejector through a special back-flow check valve and then into the nozzle venturi. The gas mixes with the ejector water and is discharged through the diffuser into the water being treated. The ejector vacuum is transmitted through the vacuum line to the rate valve and the flow meter; then through the connector on the pressure-relief (vent) valve and on to the back of the operating ammoniator diaphragm. With sufficient vacuum, the diaphragm moves backward, opening the spring-loaded inlet regulating valve to allow ammonia to enter from the cylinder. The ammonia passes through the ammoniator, the pressure-relief (vent) valve connector and the flow rate indicating meter/flow rate adjusting valve to the ejector.

When the operating cylinder starts to run out, the vacuum starts to build up in the system causing the diaphragm of the ammoniator on stand-by to be drawn back, overcoming a detent mechanism and opening the safety/inlet valve. This allows ammonia gas to be withdrawn from the "stand-by" cylinder to satisfy the increased system vacuum and the vacuum then falls back to the operating level.

The original supply cylinder also continues to feed until it is empty, virtually assuring that there will be no interruption of ammoniation and that full use will be made of all available ammonia. This also reduces the possibility and risk of returning cylinders with some remaining gas to the supplier.

SPECIFICATIONS

The ammoniator system shall be a vacuum-operated, solution-feed type and shall automatically switch the ammonia supply from an empty cylinder to a full cylinder. It shall be REGAL Model 316 manufactured by Chlorinators Incorporated, Stuart, Florida, and shall have a maximum capacity of 100 lbs./24 hrs. (2000 gms/hr).

SPECIFICATIONS (continued)

The Model 316 Vacuum-Operated Automatic Switchover Chlorinator shall consist of the following components: Two (2) automatic switchover vacuum regulators for mounting on REGAL MAN-1A wall mounted manifold assemblies, one (1) pressure-relief (vent) valve, one (1) ammonia gas flow meter panel with rate valve, & one (1) ejector/check valve assembly.

The vacuum regulators shall mount directly onto the valves of REGAL MAN-1A wall mounted manifold assemblies which in turn connect to the ammonia gas cylinders using the flexible connectors and yokes provided. The main vacuum-regulating diaphragm of each ammoniator shall have a minimum operating area of 12 sq. inches in order to achieve required accuracy and repeatability of the set ammonia flow rate. All metallic bolts shall mate with metallic threaded nuts or inserts. Plastic mating threads for metallic bolts shall not be acceptable.

Each ammoniator vacuum regulator shall have its own diaphragm, safety-shutoff/inlet valve and switchover detent mechanism, thereby, allowing ammoniation to continue should it become necessary to remove either vacuum regulator from service for cleaning or repair. Switchover detent mechanism shall be made of corrosion-resistant materials and shall not require any field adjustment.

CONTENTS GUIDE

- 2 each Model A-817 Vacuum Regulators with 3/8" Vent and Vacuum Fittings. Flowmeter and Rate Valve are on Remote Meter Panel.
 - 1 each Model A-255A Remote Meter Panel with 3/8" Vacuum Fittings (For wall mounting)
 - 1 each Model A-300AV1 Pressure Relief (Vent) Valve with 3/8" Vent and Vacuum Fittings and Wall Mounting Bracket
 - 1 each Model A-920A Ejector Assembly includes Nozzle, High Pressure Check Valve, Spray Diffuser and 3/8" Vacuum Fitting
 - 50' VT-1 3/8" Vent and Vacuum Tubing
 - 10 each G-201 Lead Cylinder Gaskets
 - 1 each Z-296 Rate Valve Tool
 - 1 each Z-297 Vent Line Bug Screen
- Approximate Shipping Weight: 17 lbs

OPTIONAL

- Low Pressure Ejector A-921A
- Hi/Lo Pressure Ejector A-927A
- MAN-1A Wall Mounted Manifold Assemblies

IMPORTANT NOTE: The REGAL MAN-1A Wall Mounted Ammonia Manifold Assembly is ordered as a separate line item. Consult CHLORINATORS INCORPORATED.

chlorinators incorporated

1044 SE Dixie Cutoff Road, Stuart, FL 34994 USA

Tel: 772-288-4854 • Fax: 772-287-3238 • www.regalchlorinators.com • E-mail: regal@regalchlorinators.com